

# TRAKER T45

450 kg · 992 lbs

**IT** Il minidumper T45 con portata massima di 450 kg è la macchina professionale più piccola della gamma. Bassa pressione al suolo e ridottissime dimensioni consentono a questa macchina di lavorare negli spazi più stretti e su ogni terreno.

**EN** T45 minidumper has 992 lbs capacity and it is the smallest professional machine of the product range. Low ground pressure and very small dimensions enable this machine to work in the narrowest spaces on any kind of terrain.

Sovraspanda  
Extra overboard



Equipaggiato con / Equipped with:  
Honda 5.5 HP – Yanmar 4.7 HP



T45 • MINIDUMPER

C&F—CONSTRUCTION EQUIPMENT



<p>1</p> <p>Motorizzazione diesel o benzina Gasoline or diesel engine</p>	<p>2</p> <p>Avviamento manuale o elettrico Manual or electric starting</p>	<p>3</p> <p>Due pompe idrauliche a ingranaggi Two hydraulic gear pump</p>
<p>4</p> <p>Trasmissione idrostatica Hydrostatic transmission</p>	<p>5</p> <p>Rulli oscillanti Rocking rollers</p>	

**VANTAGGI / ADVANTAGES**



# TRAKER T45

MINIDUMPER

CAPACITÀ OPERATIVA  
OPERATING WEIGHT  
450 kg · 992 lbs

LARGHEZZA MACCHINA  
MACHINE WIDTH  
680 mm · 26.7 inch

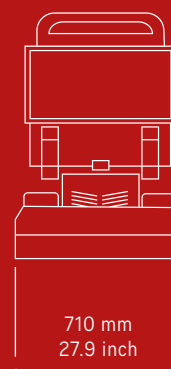
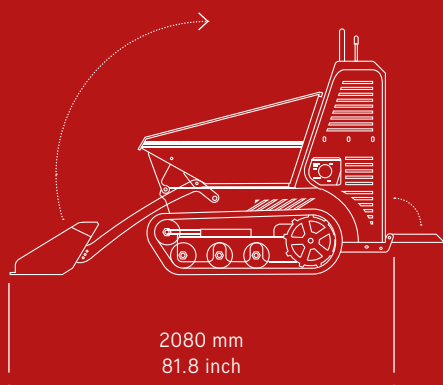
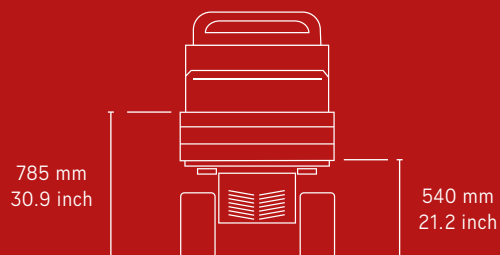
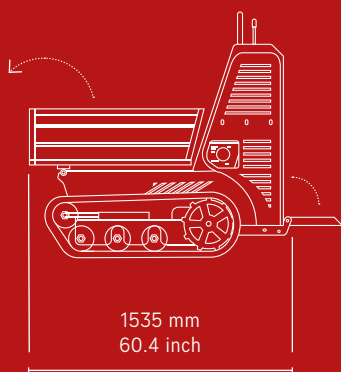
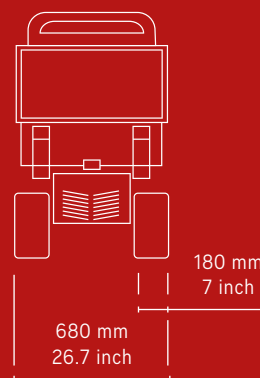
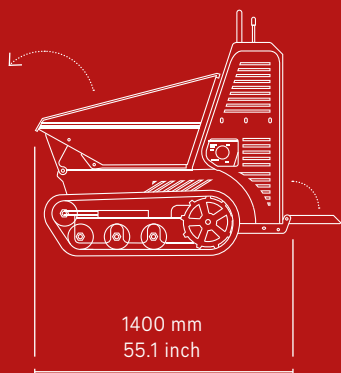

**MOTORE TERMICO**  
**ENGINE**

- HONDA GX200
- YANMAR L48N

**TRASMISSIONE**  
**TRANSMISSION**

- IDROSTATICA
- HYDROSTATIC

**POMPA IDRAULICA**  
**HYDRAULIC PUMP**

- 2 x INGRANAGGI
- 2 x GEAR PUMP

**MOTORE IDRAULICO**  
**HYDRAULIC MOTOR**

- 2 x ORBITALI
- 2 x ORBITAL

**PORTATA POMPA**  
**PUMP FLOW RATE**

- 2 x 14 l/min
- 2 x 3.8 gpm

**PRESSIONE MASSIMA**  
**MAX PRESSURE**

- 180 bar

**RAFFREDDAMENTO IDRAULICO**  
**HYDRAULIC COOLING SYSTEM**

- ARIA
- AIR

**LARGHEZZA CINGOLI**  
**TRACK WIDTH**

- 180 mm
- 7 inch

**RULLI**  
**TRACK ROLLERS**

- 3

**RULLI OSCILLANTI**  
**ROCKING ROLLERS**

- SI
- YES

**REGOLAZIONE CINGOLI**  
**TRACK TENSIONER**

- SI
- YES

**1 VELOCITÀ DI TRASLAZIONE**  
**1 TRAVEL SPEED**

- 2.5 km/h
- 1.55 mp/h

**CAPACITÀ OPERATIVA**  
**OPERATING WEIGHT**

- 450 kg
- 992 lbs

**MASSA A VUOTO**  
**EMPTY WEIGHT**

- 340 kg
- 749 lbs

**CARATTERISITCHE TECNICHE / TECHNICAL FEATURES**

 RASO 0.22 m<sup>3</sup>  
STRUCK 0.28 yd<sup>3</sup>

 COLMO 0.29 m<sup>3</sup>  
HEAPED 0.37 yd<sup>3</sup>

 RASO 0.15 m<sup>3</sup>  
STRUCK 0.19 yd<sup>3</sup>

 COLMO 0.23 m<sup>3</sup>  
HEAPED 0.30 yd<sup>3</sup>

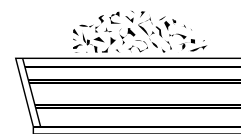
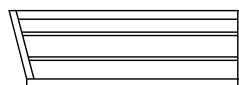
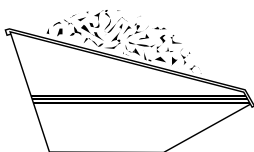
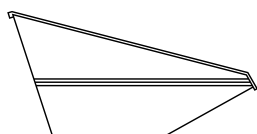

**CAPACITÀ / CAPACITY**